

# *Vinnova project*

*Increased production  
systems effectiveness  
through condition  
monitoring and prognostics*



# *Maintenance Engineering & Design*

*Starting point 2010-10-01*

A rapid expanding research group within  
Division of Operation, Maintenance and  
Acoustics

# *Organisation*

Project leader: Jan Lundberg

## **Optimum maintenance decisions of mill liners**

PhD student: Rajiv Dandotiya

Supervisor: Jan Lundberg

## **Condition monitoring of fatigue cracks in rotating mining mills**

PhD student: Filip Berglund

Supervisor: Aditya Parida

# *Sponsors*

- Vinnova
- Boliden Mineral AB
- LKAB
- Metso Minerals
- Ringhals AB



# *Optimum maintenance decisions of mill liners*

Rajiv Dandotiya, PhD student

## Part -1

# Optimum replacement interval of grinding mill liners of an ore dressing plant

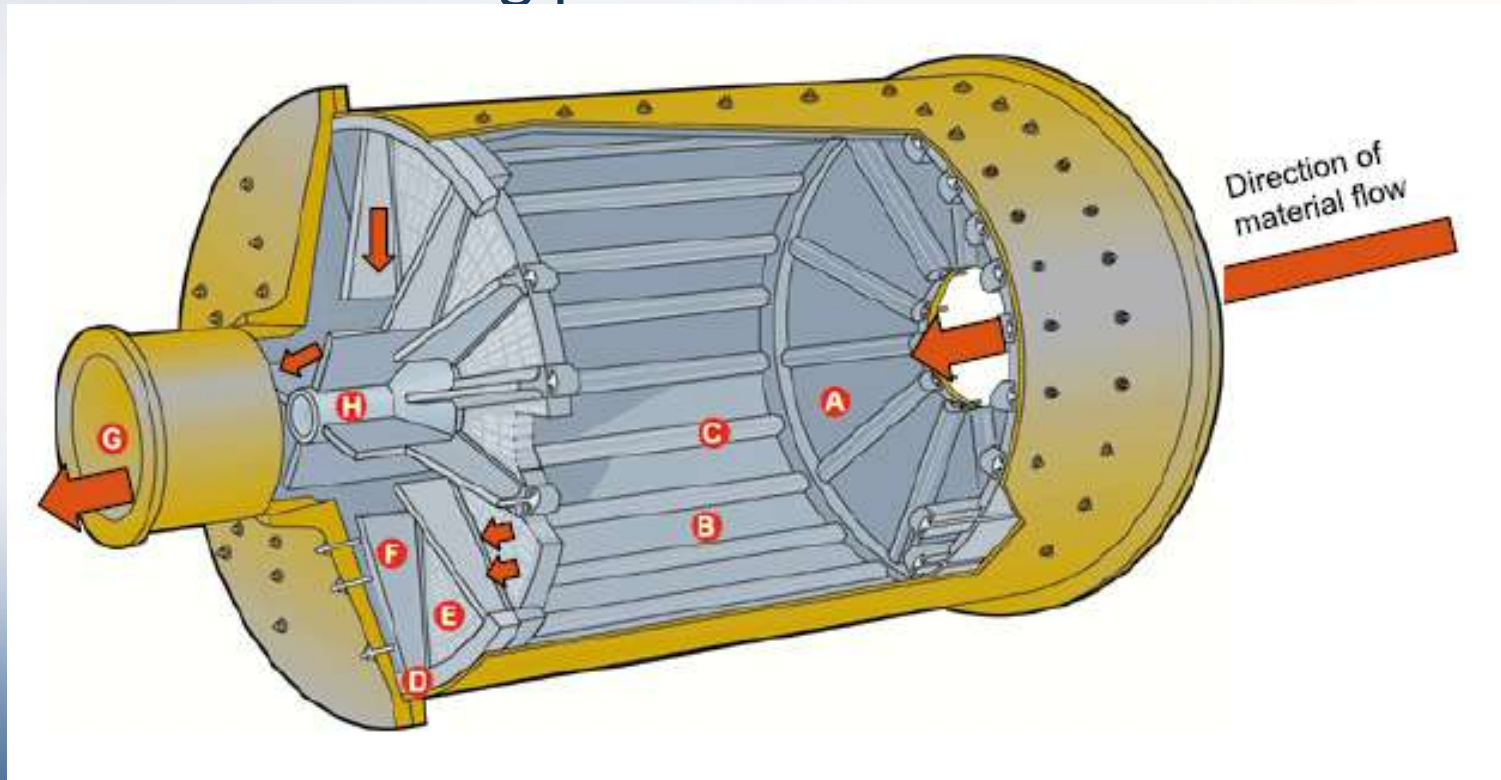

## *Objectives*

To improve the mill profit through cost effective replacement interval of mill liners,

To synchronize the process efficiency with maintenance policy for making more cost effective replacement decision

# Mathematical modeling for Life Cycle Profit (LCP)

## Annual gross profit

$$P_{gross}^l = \left( \sum_{i=1}^{T_l} M_i \cdot \Omega \cdot \eta_p - \sum_{i=1}^{T_l} E_i \cdot C_{energy} - \sum_{i=1}^{T_l} C_{insp}^i - C_{DT} \right) \times \left( \frac{n \times 365}{(T_l + T_{rep})} \right)$$

Where,  $T_l$  will vary from 1 to  $T_{Cycle}(j)$  based on ore property.

$$T_{Cycle}(j) : \text{wear life of mill liners for ore type "j"} \quad T_{Cycle}(j) = \left( \frac{\rho_{avg}}{\rho_j} \right) \cdot T_{avg}$$

$$T_{eff} = \frac{p_1 \cdot T_1 + p_2 \cdot T_2 + p_3 \cdot T_3 + \dots + p_i \cdot T_i}{p_1 + p_2 + p_3 + \dots + p_i}$$

$$P_{(i)} = p_{avg(i)} \times t_i \quad [\$]$$

# Solution approach

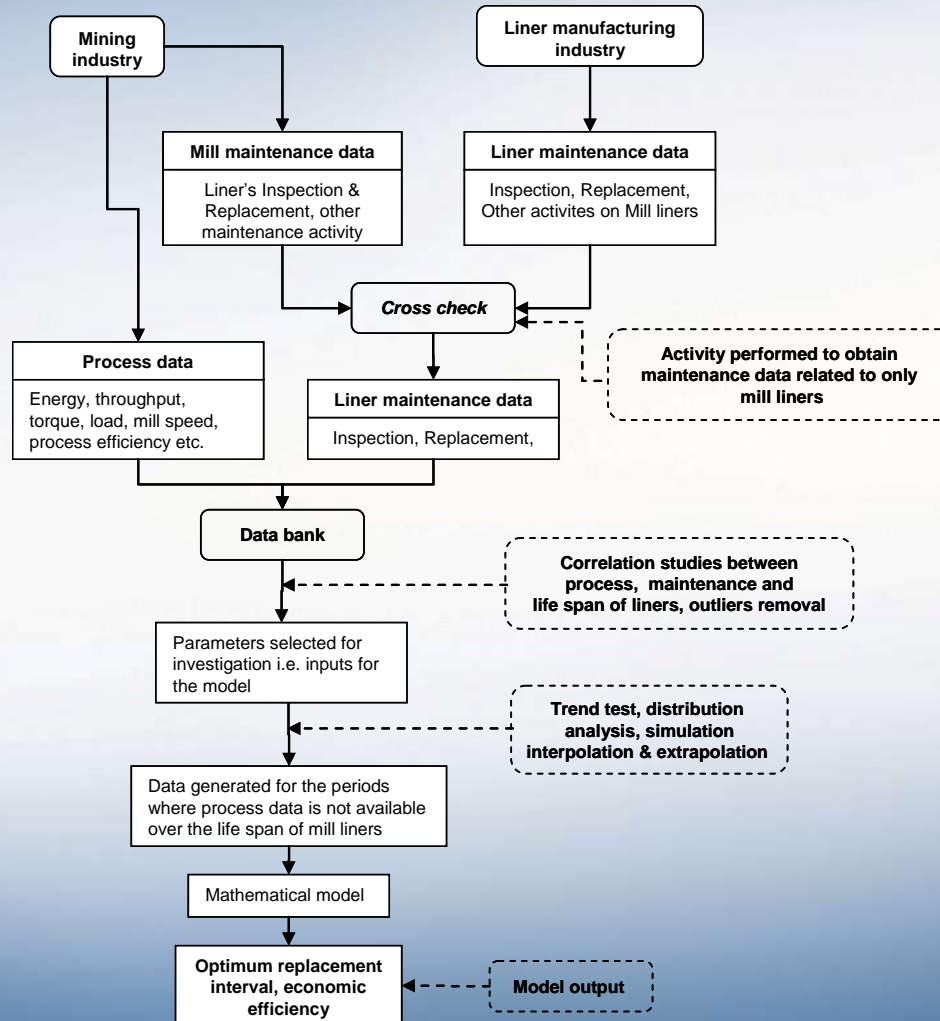

# Results

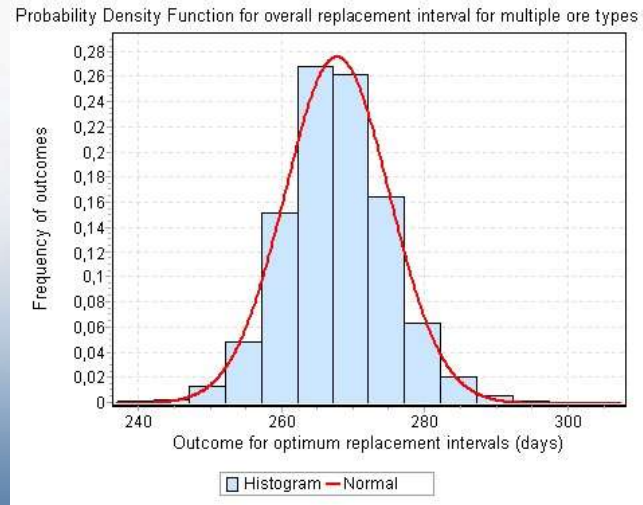
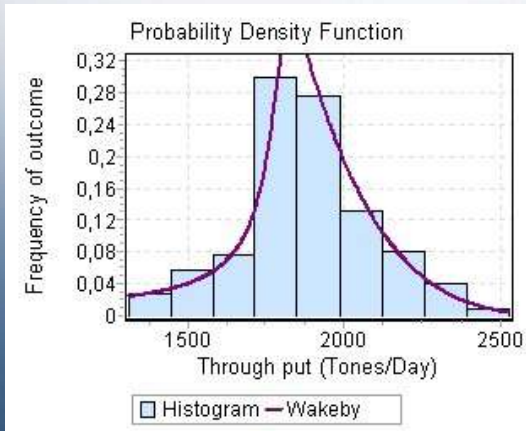
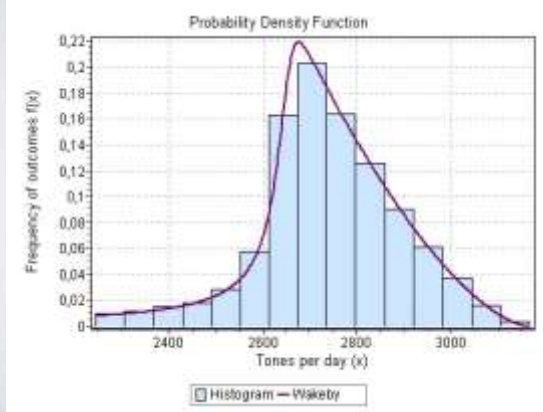
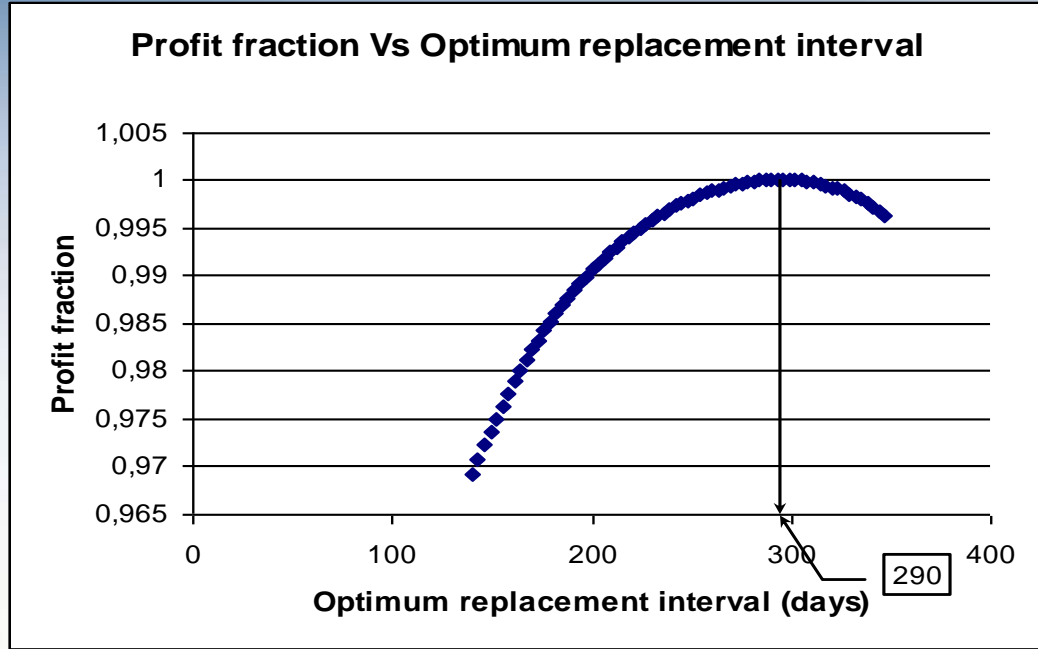
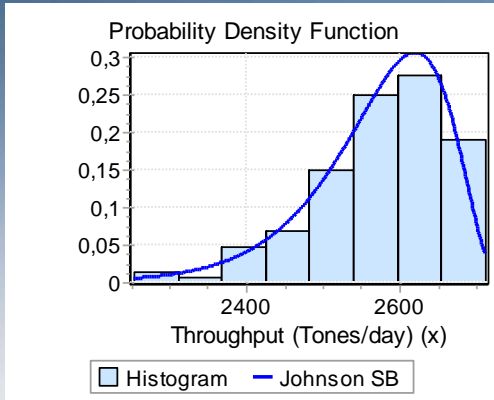

## *Conclusions for part -1*

Maintenance activities on mill liners are not only affects LCC but also affects the grinding performance of the mill.

An effective maintenance policy should consider production quality, ore properties and operation & maintenance parameters together.

An increase of 0.3% to 0.5%, with a 95% confidence interval, in the gross profit per year, can be obtained by replacing current replacement policy with optimum replacement interval.

## Part -2

Decision support system for optimum grouping and life improvement for the replacement of parts of grinding mill liners



## *Objective of the study*

To reduce the no. of mill stops for the replacement of parts of mill liners due to different wear life

To reduce the heavy monetary losses occurs due to multiple replacement occasions (production loss + startup cost)

## *The goals can be achieved by*

Optimizing maintenance scheduling (grouping) for the replacement of parts of mill liners

Optimum life improvement of parts of mill liners

# Basis of optimization

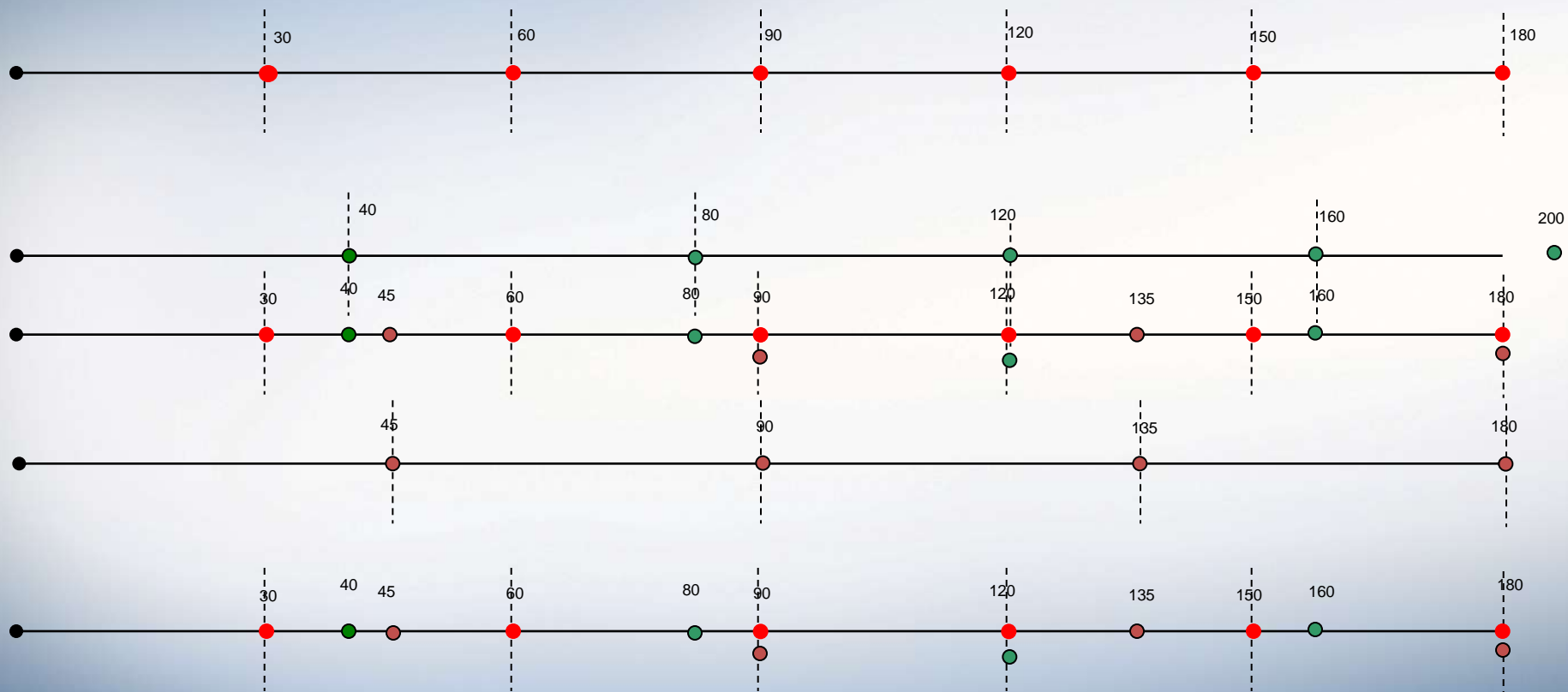

# LCC model

$$C_T^{S_i} = C_{T_x}^{S_i} + C_{T_y}^{S_i} - C_{reduction}^{S_i}$$

$C_{T_x}^S$  = (Cost of the components) + (Production loss cost during the replacement of the components)

$$C_{T_x}^S = \sum_{k=1}^i f_{c_k}^x \cdot C_k + \sum_{k=1}^i f_{c_k}^x \cdot (C_{DT} + C_{Mh}) \cdot (T_k + T_{prep})$$

$C_{T_y}^S$  = (Cost of the components) + (Production loss cost during the replacement of the components)  
+ (Cost increment for improving the life of component after rescheduling)

$$C_{T_y}^S = \sum_{k=1}^m n_{c_k}^y \cdot (C_{DT} + C_{Mh}) \cdot (T_k + T_{prep}) + \sum_{i=1}^m n_{c_k}^y \cdot C_k + \sum_{k=1}^m n_{c_k}^y \cdot T_{delay(k)}^S \cdot C_{increment}(t)$$

$$C_{reduction}^S = f_{add}^S \cdot T_{prep} \cdot (C_{DT} + C_{MH})$$

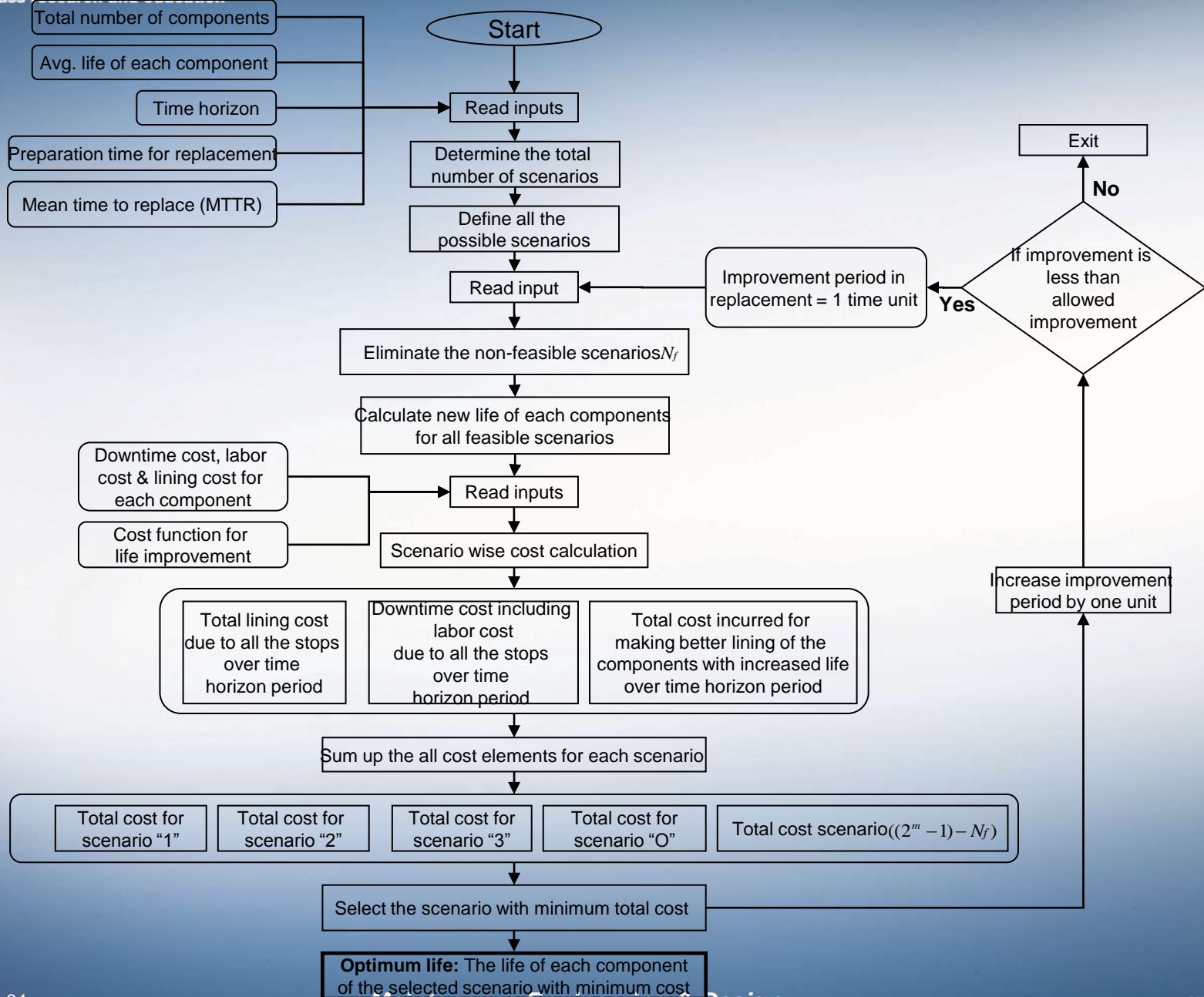

# Results

Cost vs wear life improvement

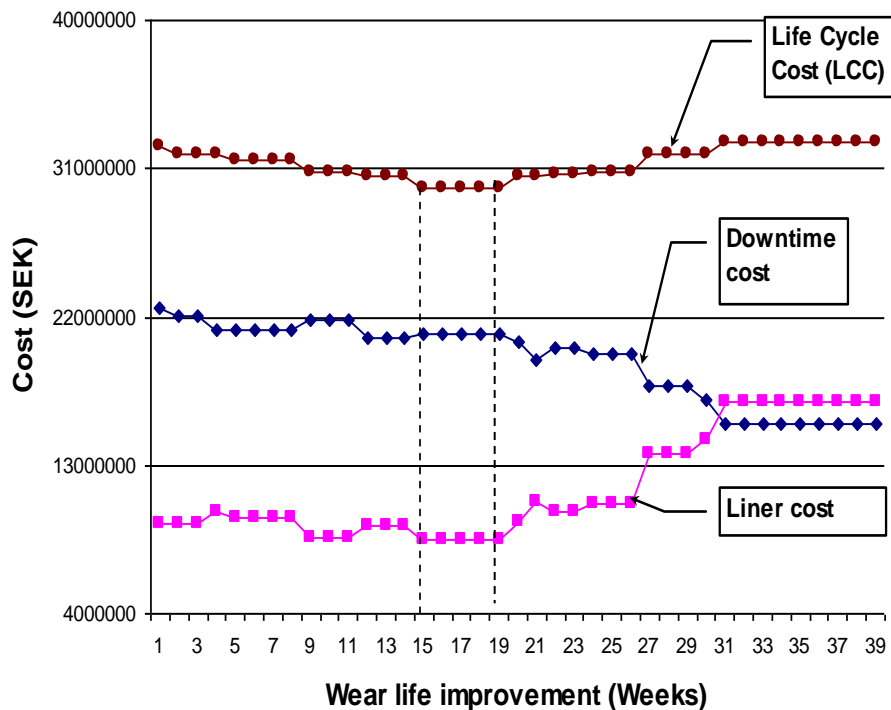

LCC vs wear life improvement





# *Demonstrator*

[8 components.xls](#)

## *Conclusions of part 2*

Life cycle cost (LCC) can be reduced by optimizing the grouping for joint replacement and necessary life improvement of the specific components of mill liners

# *Condition monitoring of fatigue cracks in rotating mining mills*

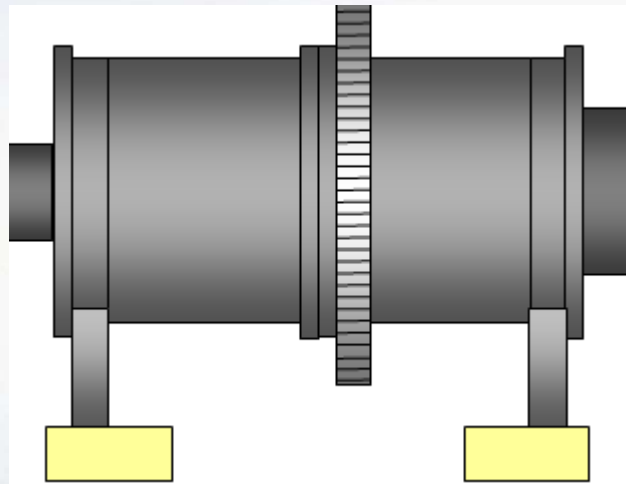

Filip Berglund, PhD student

# *Background*

- The LKAB mills work constantly under heavy and dynamic loads
- Recently, problems with fatigue cracks and unpredicted failures have started to occur in the mills

# *Objectives*

- To find and implement suitable condition monitoring methods for crack detection and monitoring.
- To find out how long the mills can be operated, before failure, once cracks are discovered. (Remaining Useful Life - RUL)

Method	Contact	Detection of internal defects	Temperature range	Flaw type	Wireless	Cost	Sensor type
Ultrasound	Yes	Yes	up to 250°C (higher temp special probes)	Surface & embedded cracks	No	Moderate to high	Probe
Eddy current	Yes	Yes	up to 150°C (higher temp special probes)	Surface & embedded cracks	No	Moderate	Probe
Acoustic emission	Yes	Yes	up to 150°C (higher temp special probes)	Surface & embedded cracks	No	Moderate to high	Probe
Magnetic particle testing	Yes	Yes	up to 100°C	Surface cracks	No	Low to moderate	Magnetic particles/wet magnetic fluorescent particles
Bleeding composites	Yes	No	N/A	Surface cracks	Yes	N/A	Film/matrix
Fatigue damage sensor	Yes	No	N/A	Surface cracks	Yes	Moderate to high	Sensor/shim
Fiber optic sensors	Yes	No	up to 200°C	Surface cracks	No	High	Optical fibre
Strain gauges	Yes	No	up to 250°C (higher temp special probes)	Surface cracks	No	Low to moderate	Gauge
Piezoelectric paint sensors	Yes	No	N/A	Surface cracks	No	High	Film/electrode
Fluorescent crack sensors	Yes	No	220°C (special coatings high temperature)	Surface cracks	No	Moderate to high	Film/matrix
Image processing - DIC	No	No	-----	Surface cracks	Yes	Moderate to high	Camera/cameras
Geometric modeling	No	No	-----	Surface cracks	Yes	High	Camera
Thermography	No	No	-----	Surface cracks	Yes	Moderate to high	IR-camera
Laser detection	No	No	-----	Surface cracks	Yes	Moderate to high	Laser
Alumina paste film	Yes	No	N/A	Surface cracks	Yes	Moderate to high	Film
Fatigue crack detection method	Yes	No	N/A	Surface cracks	Yes	Moderate to high	Film

# Investigated NDT methods

(NDT - Non Destructive Testing)

- Out of many, a few methods were found suitable for condition monitoring of mining mills
- Evaluated based on criterias with AHP method
- The top ranked methods were investigated in more detail with experiments and real life measurements

	Detectability	Reliability	Cost	Wireless	Operability	Weight	Result	Ranking
Thermography	0,37	0,21	0,11	0,27	0,16	0,49	0,28	1
DIC	0,12	0,25	0,26	0,26	0,36	0,23	0,20	3
Fatigue damage sensors	0,19	0,23	0,07	0,09	0,08	0,10	0,17	4
Piezoelec. paint sensors	0,07	0,08	0,20	0,06	0,13	0,09	0,09	5
Fluorescent crack sensors	0,25	0,23	0,36	0,31	0,26	0,10	0,26	2

# *Experiments & measurements*

- The mills and kiln in LKAB have been scanned with infrared (IR) thermal camera
- Fatigue crack growth measurements have been performed with fatigue sensors attached to the mill
- Health monitoring with thermography of kilns are known and widely used by the industry
- LKAB has already initiated to incorporate thermography for monitoring of their kilns
- The application of thermography and fatigue sensors for crack detection and monitoring are however new for mining mills

# *IR thermography measurements, facts & hypothesis*

- **Fact:** The temperature inside the mill is higher than the temperature outside the mill. Heat always transfers from warmer to colder places (second law of thermodynamics). Because of this heat will flow out through the mill.
- **Hypothesis:** If a crack appears in the mill more heat will flow out through the crack than through the surrounding material. The rising temperature around the crack should then be possible to measure with IR-camera. By this the crack can be found and its propagation monitored.



# *Thermal mapping at the LKAB dressing plant, compilation movie*

# Snap shots from the movie

IR-images taken on a AG mill head

Reason to temperature difference: Crack, temp. diff.  $\sim 1^\circ\text{C}$

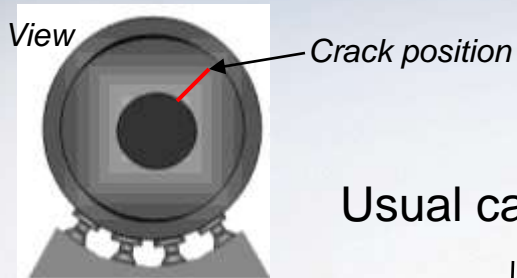

Usual case, crack free part

Crack

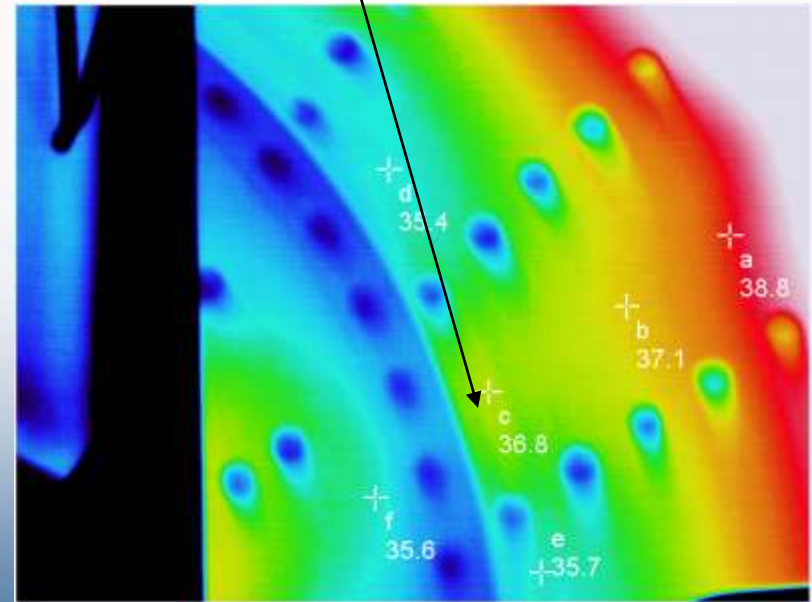
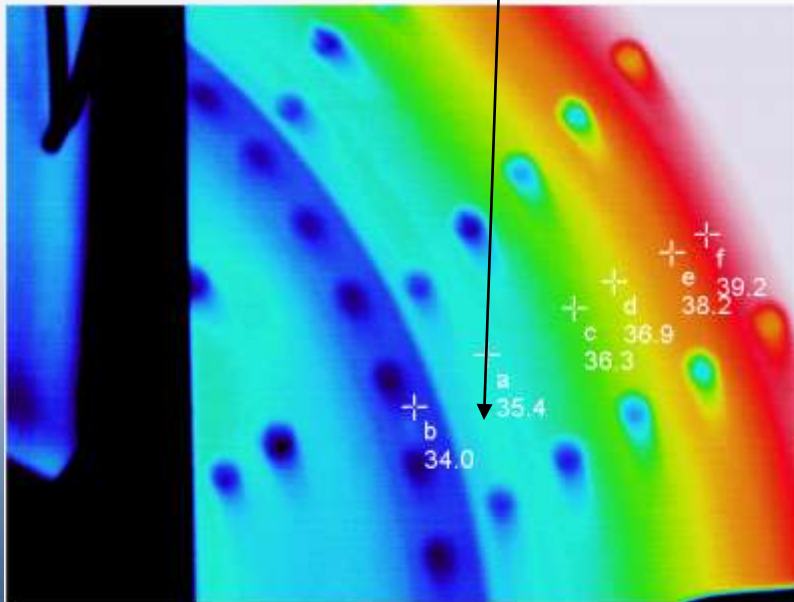

# IR-images taken on a AG mill shell

Reason to temperature difference: Linings probably not sufficient attached to the mill, temp. diff.  $\sim 0.5\text{ }^{\circ}\text{C}$

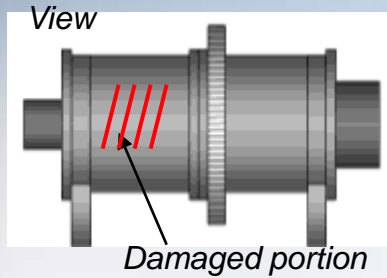

Usual case

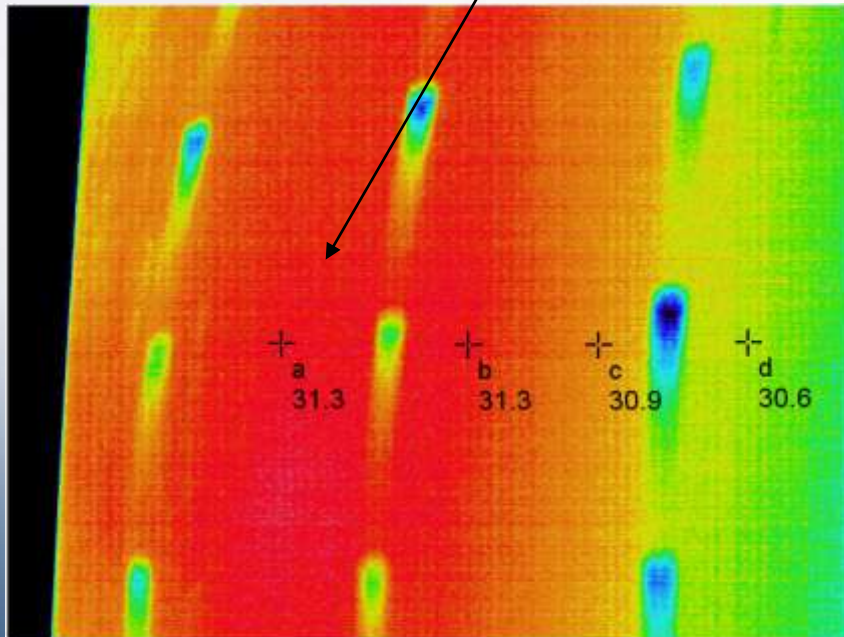

Area of lose linings

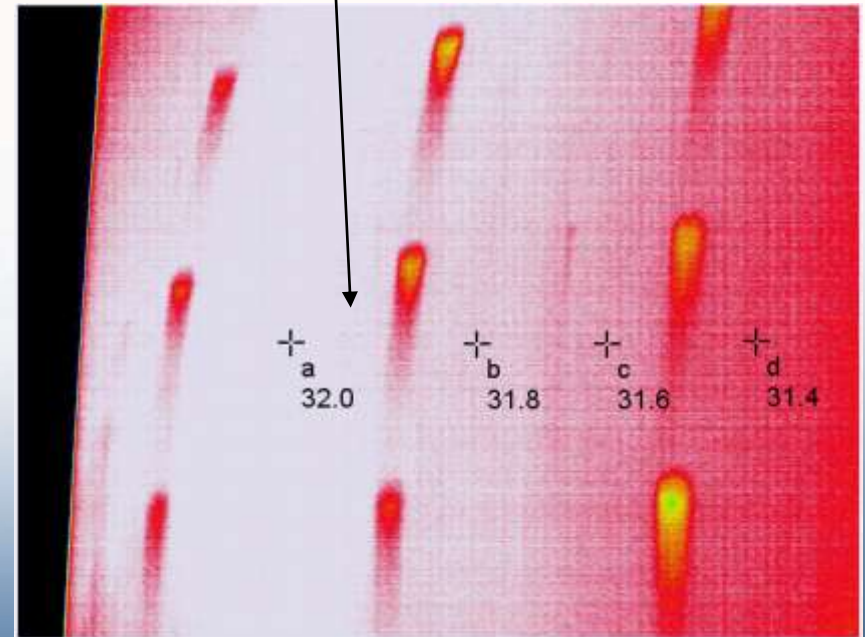

# IR-images taken on a SAG mill head

Reason to temperature difference: Crack, temp. diff.  $\sim 1\text{ }^{\circ}\text{C}$

Crack position

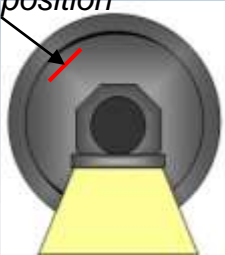

View

Usual case, crack free part

Crack

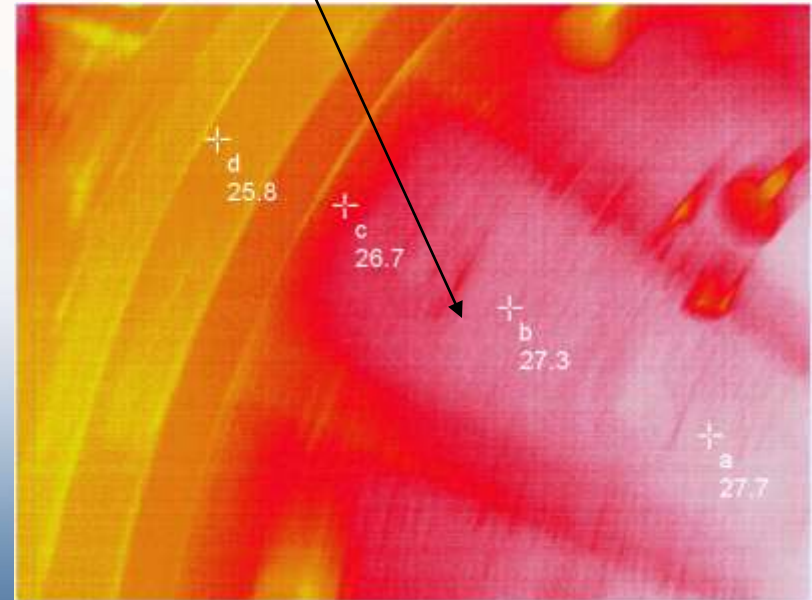
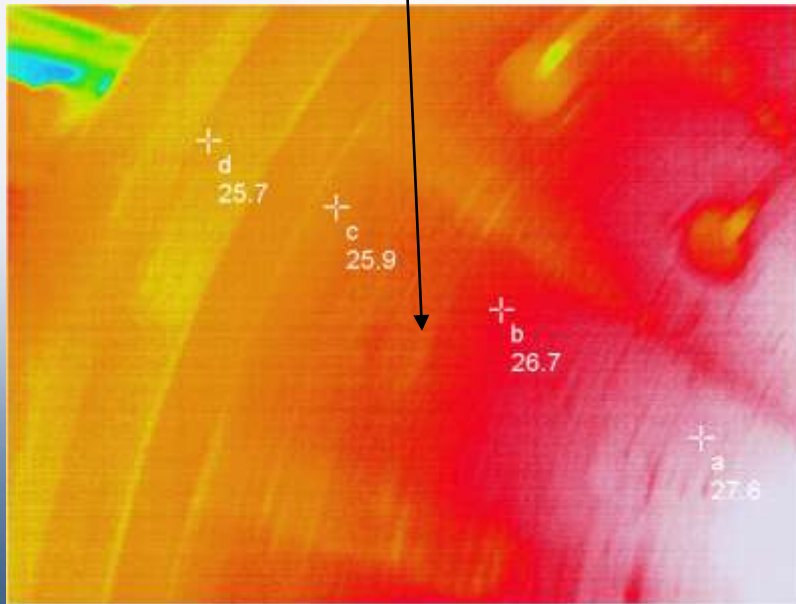

# *IR thermography measurements, advantages and disadvantages*

## **Advantages:**

- Fast scanning
- Can be used as both movable and stationary condition monitoring
- Relatively cheap and user friendly
- Mill does not need to be stopped during measurement

## **Disadvantages:**

- Not possible to get the exact location and extent of the damage
- The harsh mining environment covers the lense with dust and dirt

## *IR thermography measurements, conclusions*

- From the performed measurements it is reasonable to believe that IR-camera can be used to find and monitor fatigue cracks and other material damage in rotating mining mills
- The crack propagation can be monitored, but not in detail. Rough estimation of the crack growth can possibly be done.
- The temperature on the mill surface are affected by cracks as well as material thickness and thermal conductivity (affected by welding)
- The method is more suitable for kiln than mill, because of higher temperature and lower rotation speed.
- Faster cameras with higher sensitivity can possibly make the thermography method more suitable for mills (will be investigated).
- The technique can be used to first find damaged locations without stopping the mill, the damaged locations can then be further investigated during the next maintenance stop.

# Fatigue damage sensor measurement

- Sensors are placed at the crack tips
- The sensor matrix consists of many thin conductive wires
- As the crack propagates through the matrix, the wires break and the resistance increases in the circuit
- From this, the crack propagation can be written as a function of the voltage in the circuit, see graph.

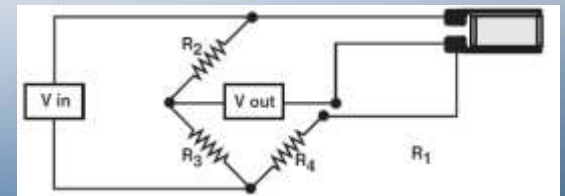
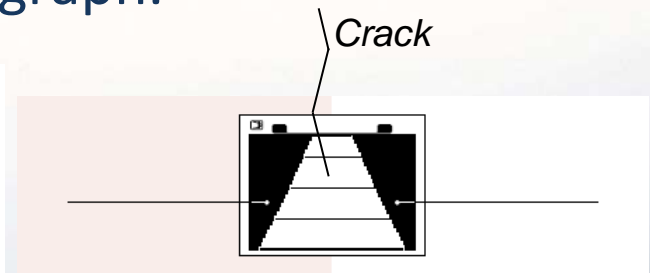
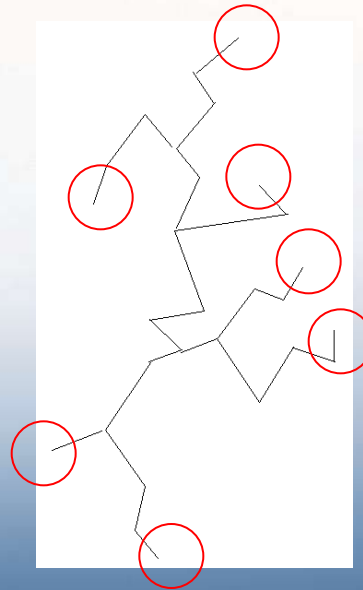
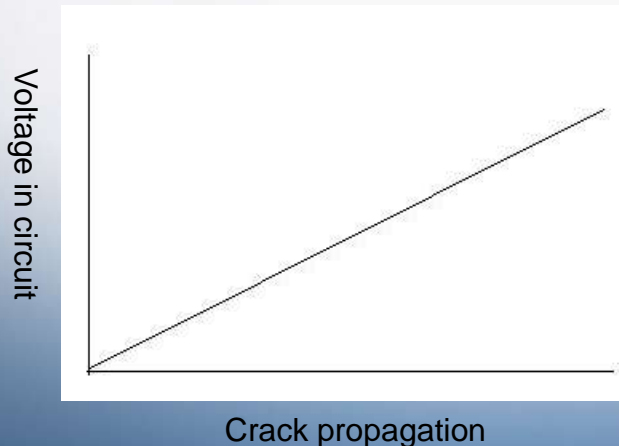

# Fatigue damage sensor measurements, advantages and disadvantages

## Advantages:

- Wireless (but, requires battery or advanced setup)
- Measures the real crack propagation

## Disadvantages:

- Contact method
- Mill needs to be stopped during fixation
- Time consuming and no easy fixation duo to wiring and connectivity setup
- Not optimal for harsh conditions. More suitable for lab conditions, when measuring the propagation of small cracks. (Ex: fatigue cracks in engine blocks)
- Crack often growth with many crack tips
- Many crack tips need to be monitor, which means many sensors are to be placed

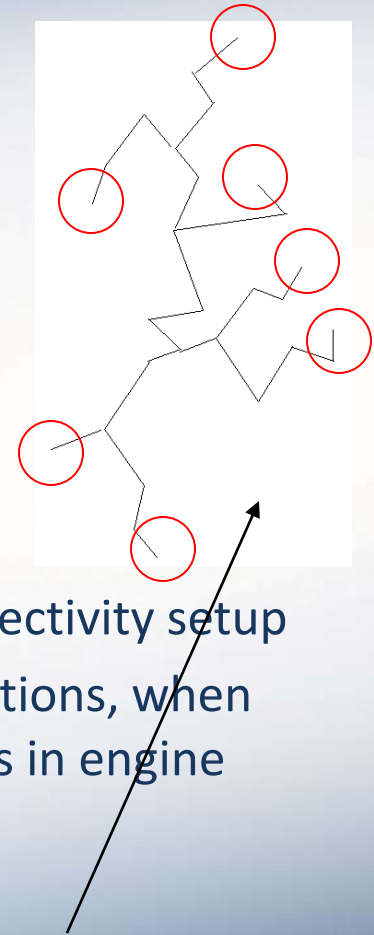

## *Fatigue sensor measurements, conclusions*

- The cracks in the mills are often too large for the sensors
- Good method for small and slow propagating cracks when high precision in the crack propagation measurements are required
- Today not optimal method for monitoring of fatigue cracks in mining mills.
- The method can however be improved and modified to be more suitable for the application



***Thank you !!***