



Nitrogen effluents from mine sites: Environmental effects and removal of nitrogen in recipients

A Strategic Mining Research Programme funded by VINNOVA, LKAB,
Boliden Mineral and The Adolf H Lundin Charitable Foundation

Project period: 2007–2011

Anders Widerlund¹, Sara Chlot¹, Roger Herbert², Björn Öhlander¹

¹Division of Geosciences, Luleå University of Technology

²Department of Earth Sciences, Uppsala University



Participating universities and researchers

Luleå University of Technology, Division of Geosciences

- *Björn Öhlander*, project leader
- *Anders Widerlund*, senior researcher
- *Sara Chlot*, Ph D student

Uppsala University, Department of Earth Sciences

- *Roger Herbert*, senior researcher





Focus area

Decreased environmental effects from mining operations

The project is directed towards ***Decreased environmental effects from mining operations***, which is one of five focus areas defined by the Swedish mining industry regarding research and development

VISION OF THE FOCUS AREA

The environmental effects from present and future mines are sustainable in a long-term perspective



Research within the focus area

Research within the focus area is directed towards:

- Improving the understanding of the distribution and natural variations of concentrations of metals, nutrients and other elements that are common in mineralized areas
- A better understanding of ecosystem adaptation and resilience regarding environmental effects from elements occurring in mineralized areas

Studies of nitrogen effluents from mine sites are a part of this focus area



Why study nitrogen in mining recipients?

Nitrogen sources in the mining industry

- Ammonium nitrate based explosives (ANFO) used in mining operations
- Sodium cyanide (NaCN) used in gold extraction from sulphide ores

Potential problems with nitrogen in mine water recipients

- Nitrogen is released into streams and lakes in forms that are available as nutrients to plants and algae (ammonium and nitrate)
- The added amount of nutrients will increase plant growth to undesired levels (eutrophication), and the species composition in plant and algae communities may change

Aquatic plants in eutrophicated lake



There is a need to reduce nitrogen effluents from mine sites and to increase nitrogen removal in mine water recipients



Field area at Boliden

Boliden–Brubäcken–Skellefte-River

- Nitrogen effluents are dominated by ammonium (~5 mg/l) from the Boliden plant
- Nitrate: ~1 mg/l
- Phosphorus: ~300 µg/l
- Dilution ~400 times from Brubäcken to Skellefte River

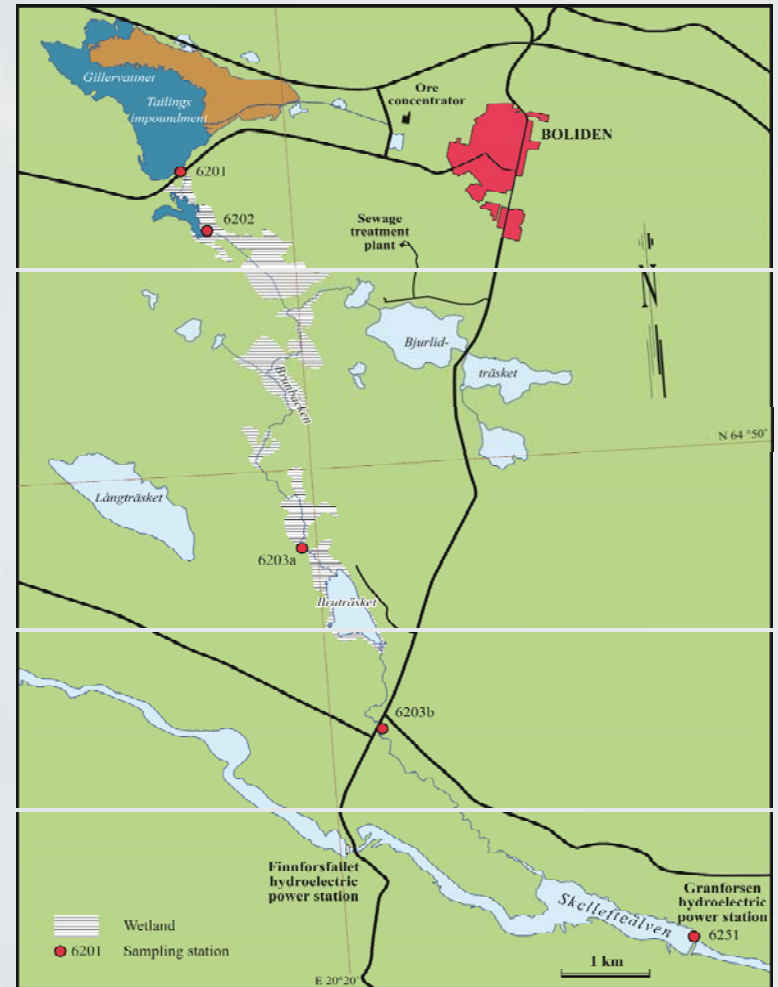

Sampling at 5 locations along Brubäcken



Field area at Kiruna

Kiruna–Rakkurijoki–Kalix-River

- Nitrogen effluents are dominated by nitrate (≤ 20 mg/l) from the Kiruna mine
- Ammonium: ~ 0.1 mg/l
- Phosphorus: ~ 30 $\mu\text{g/l}$
- Dilution ~ 100 times from Rakkurijoki to Kalix River

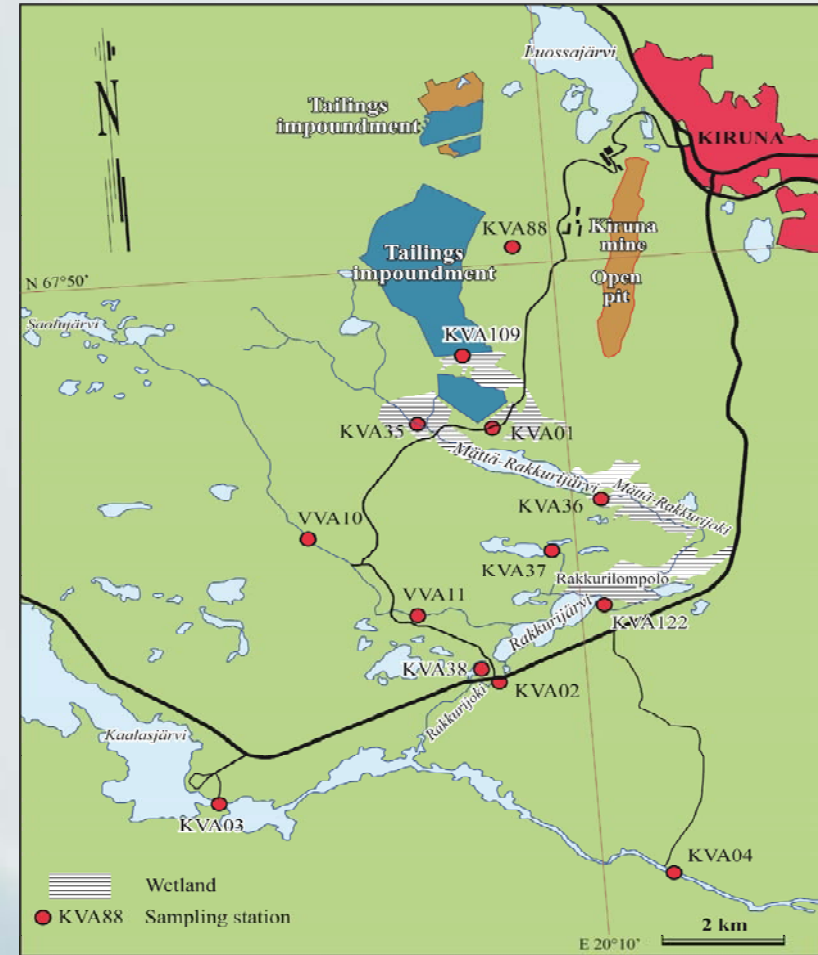

Sampling at 13 locations in the Rakkurijoki system



Four main research topics

1. Forms of nitrogen, environmental effects and natural removal of nitrogen in mine water recipients at Kiruna and Boliden
2. Installation of a pilot-scale reactive barrier for nitrogen removal at the Malmberget iron mine
3. Studies of the relative importance of nitrogen and phosphorus for eutrophication in mine water recipients
4. Studies of nitrogen concentrations and transport in the Kalix and Skellefte Rivers downstream of Kiruna and Boliden



Field data Boliden (2001-2008)

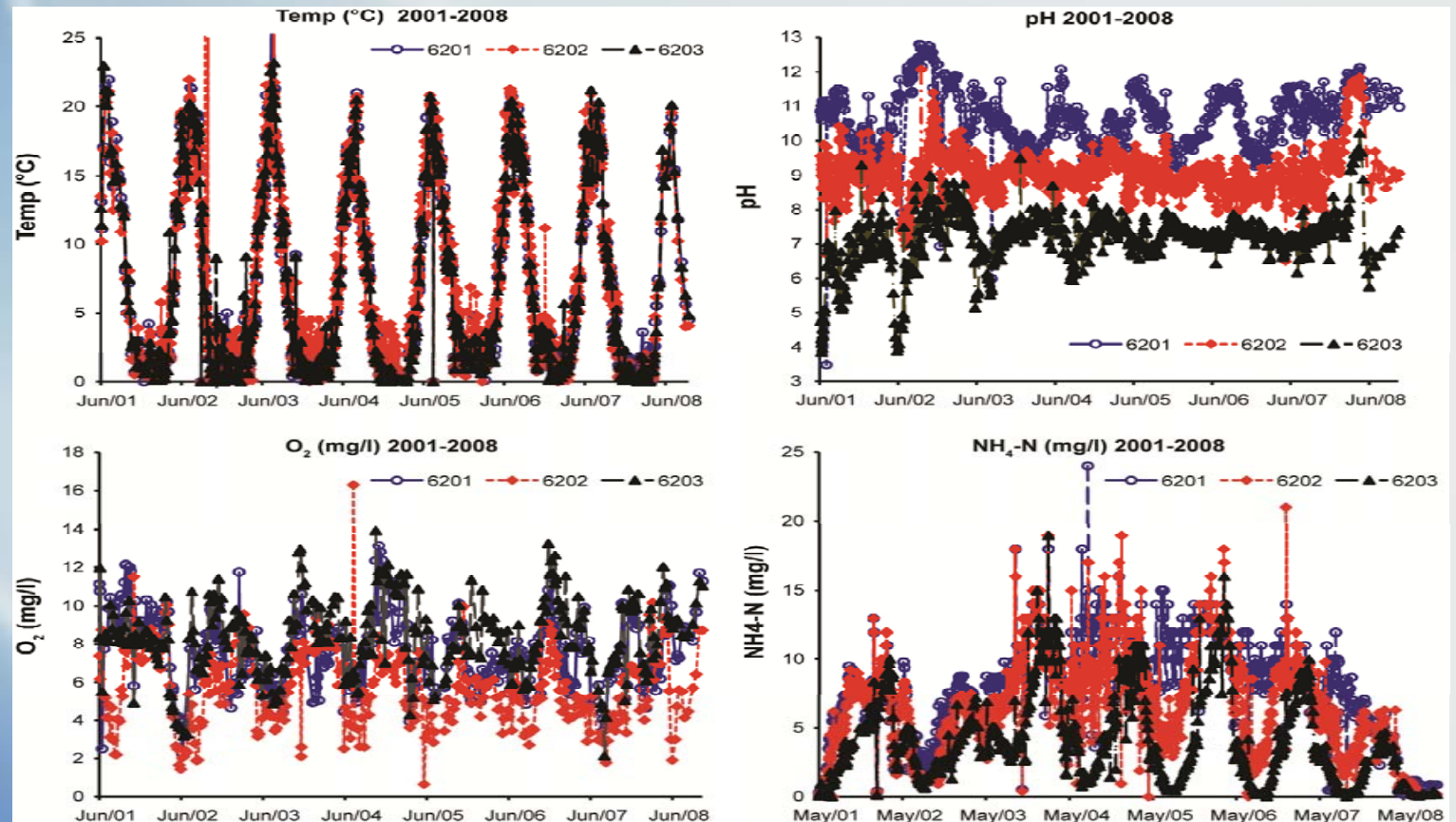

Clear seasonal variations, with lower ammonium concentrations during summer.

Possible explanations: dilution during springflood, biological uptake by aquatic plants, and oxidation of ammonium into nitrate



Conceptual model of nitrogen transformations in lakes

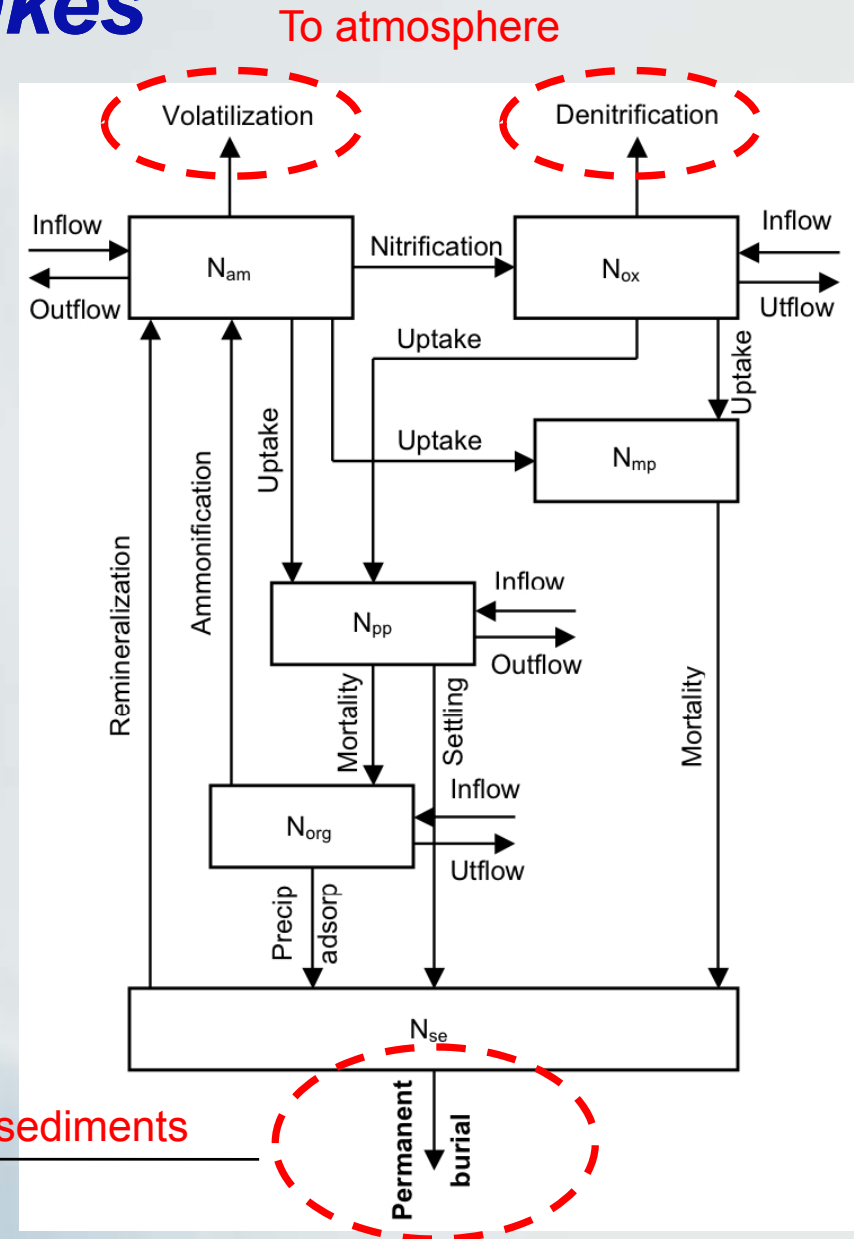
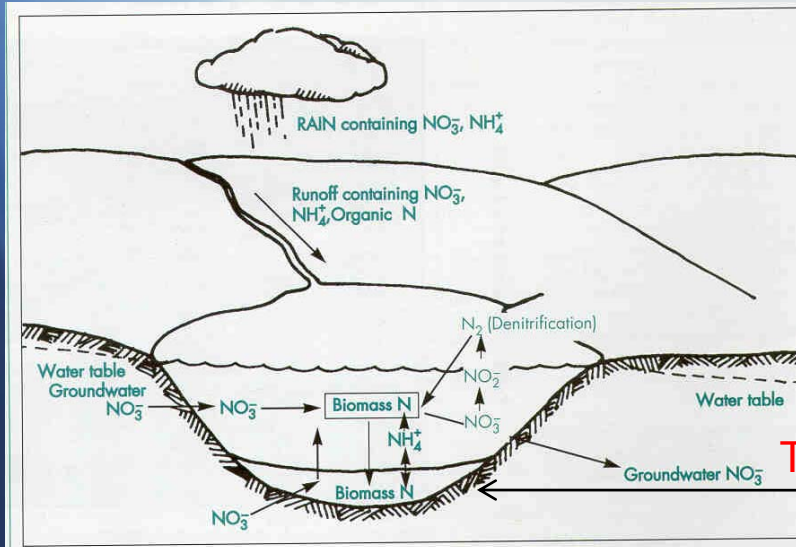
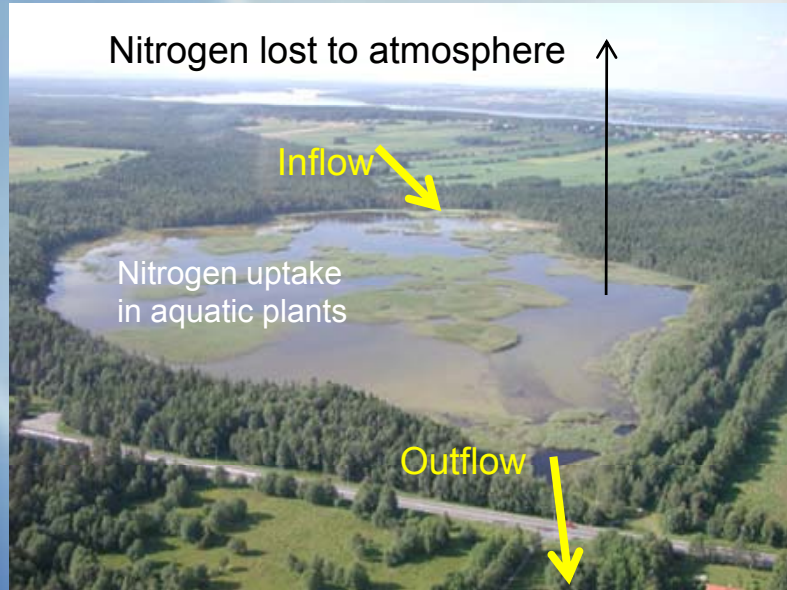

Computer simulation of nitrogen transformations in lakes

- The model is calibrated using field data from lakes at Boliden and Kiruna
- Nitrogen transformations by different processes can be quantified
- The model will be tested in lakes of different size and in systems dominated by ammonium or nitrate

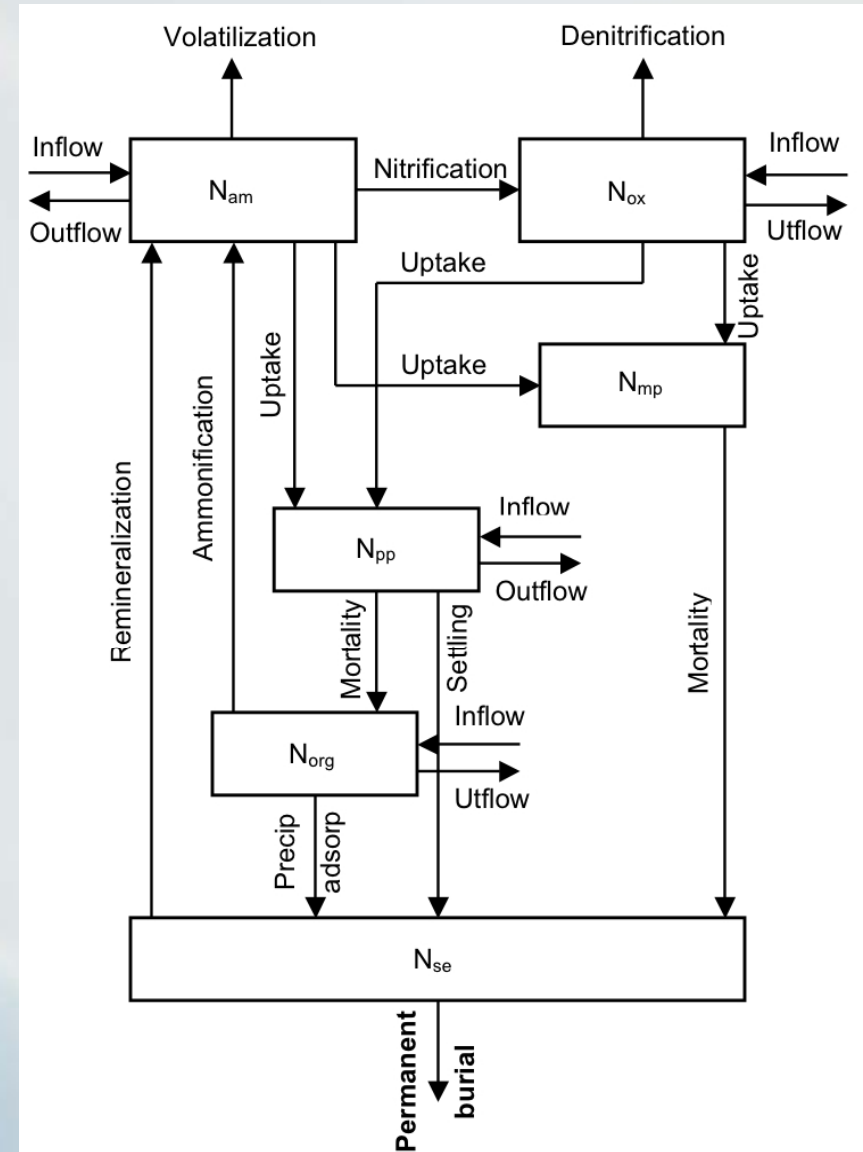

Comparison between measured data and simulations for Nya Sjön, Boliden

Simulation of ammonium and nitrate concentrations in the lake during 2008

- Good correlation between measured and simulated ammonium
- Model needs to be improved or better calibrated for nitrate

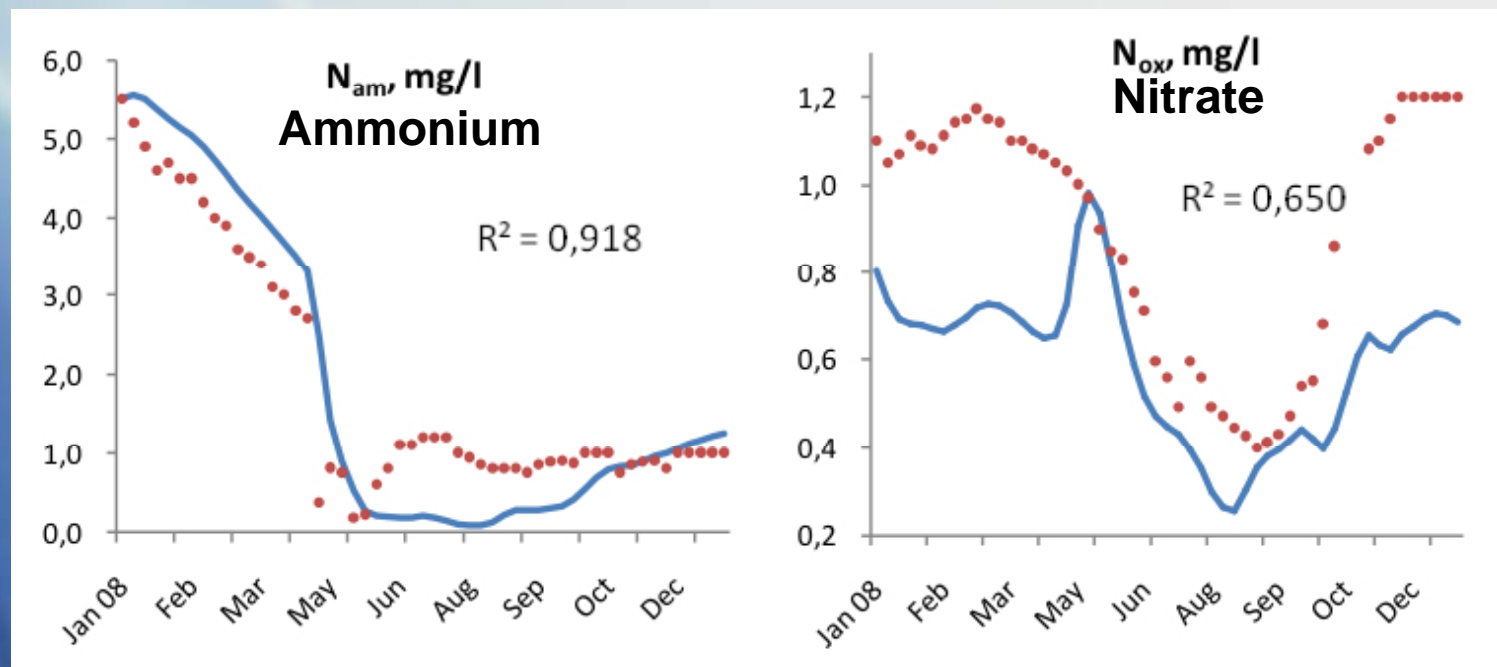

Measured data (•) and simulations (—)



Nitrogen removal at the Malmberget mine

Pilot-scale reactive barrier

The possibility to remove nitrate by transforming it into nitrogen gas in an engineered, reactive barrier is investigated

The nitrate removal capacity of a pilot-scale barrier will be investigated at the Malmberget mine

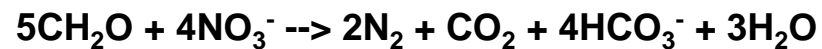

Barrier installation

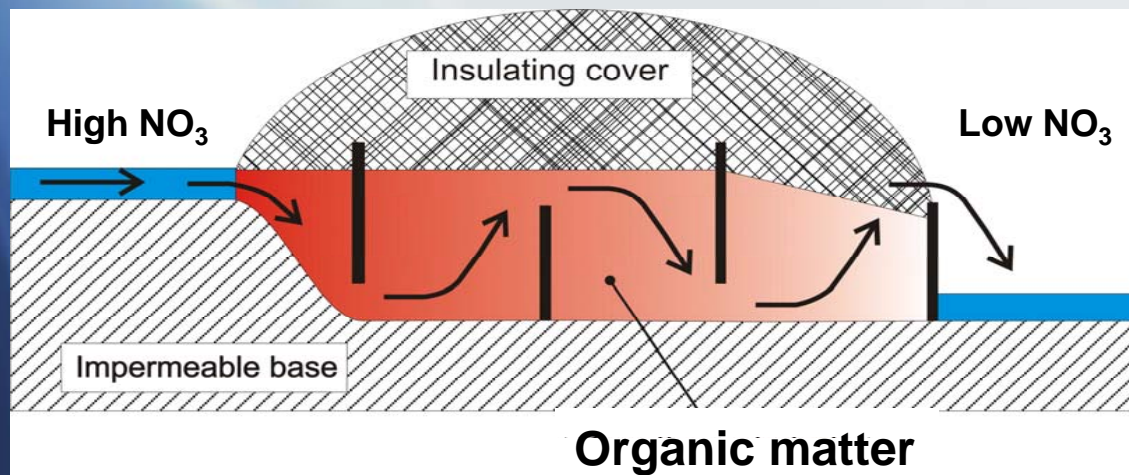

May be useful for minor water discharges with high nitrate concentrations



Expected outcomes

- Development of a quantitative model for nitrogen and phosphorus in mining recipients, that will be useful as a decision support tool for development of strategies to prevent eutrophication
- Quantification of nitrogen removal in natural recipients and engineered reactive barriers
- Determination of the relative importance of nitrogen and phosphorus for eutrophication in mine water recipients

